

**BOARD OF YAKIMA COUNTY COMMISSIONERS
PUBLIC HEARING**

Date: December 3, 2019
Re: **FINANCIAL SERVICE: 2020 Budget; *Craig Warner Presenting:***
Time: 10:00 am
Location: City Council Chambers, 129 North Second St, Yakima, Washington
Present: Chairman Mike Leita, Commissioner Norm Childress, Commissioner Ron Anderson
Legal Counsel Paul McIlrath, Deputy Clerk of the Board Linda Kay O'Hara

Record of Proceedings

Craig Warner, Budget Director, presented a Power Point Presentation. (See attached).

Public Comment:
None.

The hearing was closed.

Approved this 10th Day of December 2019:

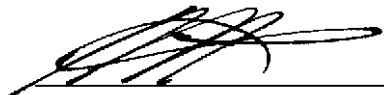

Michael D. Leita, Chairman

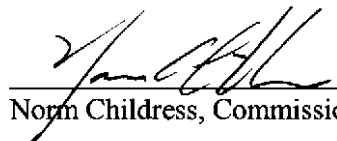

Norm Childress, Commissioner



Ron Anderson, Commissioner

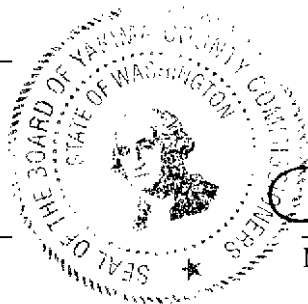



Melissa Paul, Clerk of the Board

Audio/Video transcription of this hearing accompanies this Record of Proceedings

ATTENDANCE ROSTER FOR PUBLIC HEARINGS

HEARING DESCRIPTION: 2020 Budget Hearing
DATE: 12.4.19
TIME: 7:00 PM

PLEASE SIGN IN IF YOU PLAN TO GIVE TESTIMONY

NAME (PLEASE PRINT)	MAILING ADDRESS
Jeanna Hernandez	jeanna.hz@gmail.com

2020 YAKIMA COUNTY BUDGET PRESENTATION

Yakima County Commissioners Agenda

Yakima City Council Chambers

December 3, 2019

2020 General Fund Budget

- ▣ Use the Priorities of Government Budgeting Model
 - Eight Priorities (Law, Justice, Public Safety, Public Services, Government Services, Economic Development, Quality of Life, Health and Human Services)
 - Policy Driven – (Resource Allocation, Outside Revenue, Budget, Contingency, and Reserve)
 - Budget Elected Team (BET)
 - ▣ Includes all County Elected Officials (Assessor, Auditor, Clerk, Commissioners, Coroner, Courts, Prosecutor, and Sheriff)

2020 General Fund Budget

- ▣ Revenue Budget of \$66,838,676
- ▣ Expense Budget of \$68,897,307
Reserve Used (\$ 2,058,631)
- Use of Available Cash Flow Reserves of (\$1,366,024)
- Use of Other Designated Reserves of (\$692,607)
 - ▣ Contingency Reserve Budgeted Use (\$ 109,008)
 - ▣ Elections Reserve Set Aside (\$ 115,820)
 - ▣ Court Restricted Reserves (\$ 462,779)
 - ▣ 2019 Juvenile Donation Carryover (\$ 5,000)
- ▣ Cash Flow Reserve at 11.0% (\$7.34 million)
 - (Minimum 11% per County Policy)

2020 General Fund Budget

▣ **General Revenues** \$56,602,051

▣ General Revenues – 1.95% Increase

▣ **Grants & Contracts** \$ 8,036,625

▣ Grants & Contracts – \$780 Decrease

▣ **Total General Fund Revenue** \$64,638,676

▣ Total General Fund Revenue – 1.70% increase

▣ **Road Tax Levy Shift** \$ 2,200,000 -No Change

▣ **Total General Fund Revenue** \$66,838,676

▣ Total General Fund Revenue – 1.64% Increase

2020 General Fund Budget

▣ General Revenue Changes (2019-2020)

▣ Property Tax (1% + New Construction)	\$ 560,000
▣ Sales Tax	\$ 515,000
▣ Investment Interest	(\$ 95,000)
▣ Motor Vehicle Criminal Justice Excise Tax	\$ 75,000
▣ Election Services	(\$ 82,956)
▣ Other (Contracts/Fines/Fees/etc.)	<u>\$ 108,029</u>

Total General Revenue Change

\$ 1,080,073

Grants/Contracts

(\$ 780)

1.64% Increase

Local Schools
 State School
 Cities
 County Road
 Fire Dist.
 Other

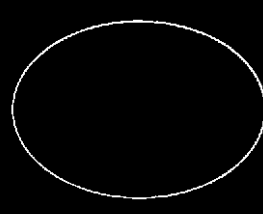

Year	Local Schools	State School	Cities	County Road	Fire Dist.	Other
2018	33.58¢	23.94¢	13.42¢	5.79¢	3.91¢	6.61¢
2019	29.46¢	24.44¢	14.49¢	6.22¢	4.61¢	7.11¢

Based on 2019 property taxes

2020 General Fund Revenue

\$66,888,676

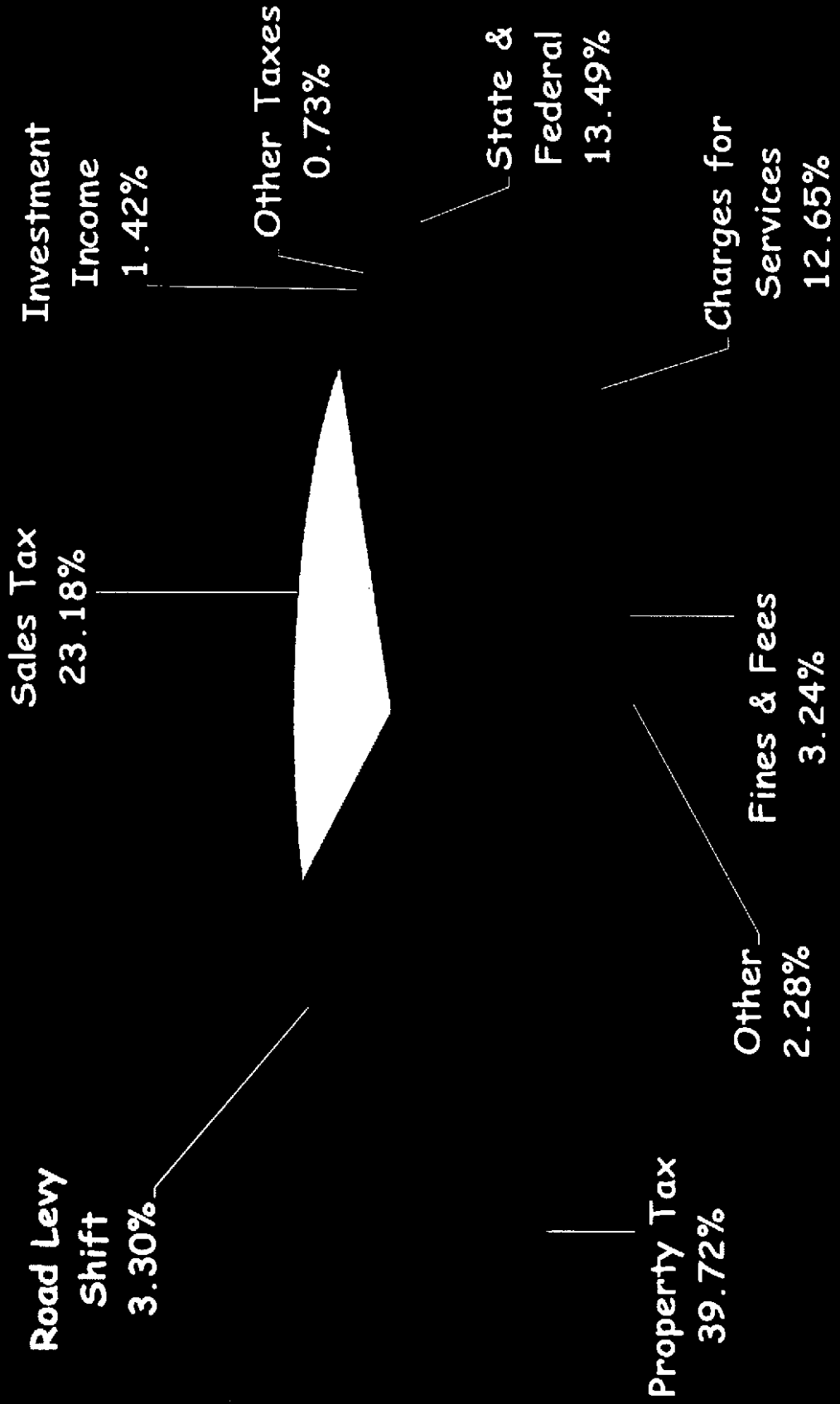

2020 General Fund Budget

-
- Expenses – \$1,424,052 (2.11%) greater than 2019
- Highlight Changes
 - Labor Costs \$ 887,713
 - Internal Service Costs \$ 433,960
 - Public Safety-Training \$ 51,700
 - Code Enforcement \$ 89,581
 - 2019 One-time Expenses (\$ 640,386)
 - 2020 One-time Expenses \$ 568,230

2020 General Fund Budget

- ▣
- ▣ One-Time Expenses \$568,230
 - Homeless Shelter (2019 Carryover) \$ 300,000
 - Elections Costs for Presidential Primary \$ 101,230
 - Code Enforcement-Legal \$ 50,000
 - Yakima County Water Resource Services\$ 25,000
 - Evidence Enclosure \$ 92,000

2020 General Fund Expense Budget

Elected	2019 Budget	2020 Budget	Change	%
Assessor	\$2,429,739	\$2,437,490	\$7,751	0.32%
Auditor	\$3,026,838	\$3,135,471	\$108,633	3.59%
Treasurer	\$1,569,649	\$1,566,754	(\$2,895)	(0.18%)
Coroner	\$367,345	\$484,763	\$117,418	31.96%
Sheriff	\$10,821,768	\$11,424,336	\$602,568	5.57%
Attorney	\$7,387,428	\$7,731,719	\$344,291	4.66%
Clerk	\$2,383,353	\$2,367,041	(\$16,312)	(0.68%)
Courts	\$12,075,391	\$12,258,041	\$182,650	1.51%
BOCC	\$27,411,735	\$27,491,692	\$79,957	0.29%

2020 General Fund Expense Budget

BOCC	2019 Budget	2020 Budget	Change
Commissioners	\$959,329	\$981,188	\$21,859
Human Resources	\$790,223	\$805,170	\$14,947
Non-Departmental	\$3,146,483	\$3,069,080	(\$77,403)
DOC	\$15,846,154	\$15,846,154	\$0
Capital Outlay	\$125,105	\$125,105	\$0
Assigned Counsel	\$3,762,860	\$3,776,802	\$13,942
AC-Experts	\$255,459	\$255,459	\$0
WSU Extention	\$345,959	\$345,989	\$0
Planning	\$2,180,163	\$2,286,745	\$106,582

2020 General Fund Expenses

\$68,897,307

Public Safety
41.58%

Governmental
Services
14.37%

Law
20.86%

Quality of Life
0.15%

Justice
18.06%

Health & Human
Services
0.65%

Economic
Development
0.00%

Public Services
3.89%

2008 - 2020 GF Revenue/Expense

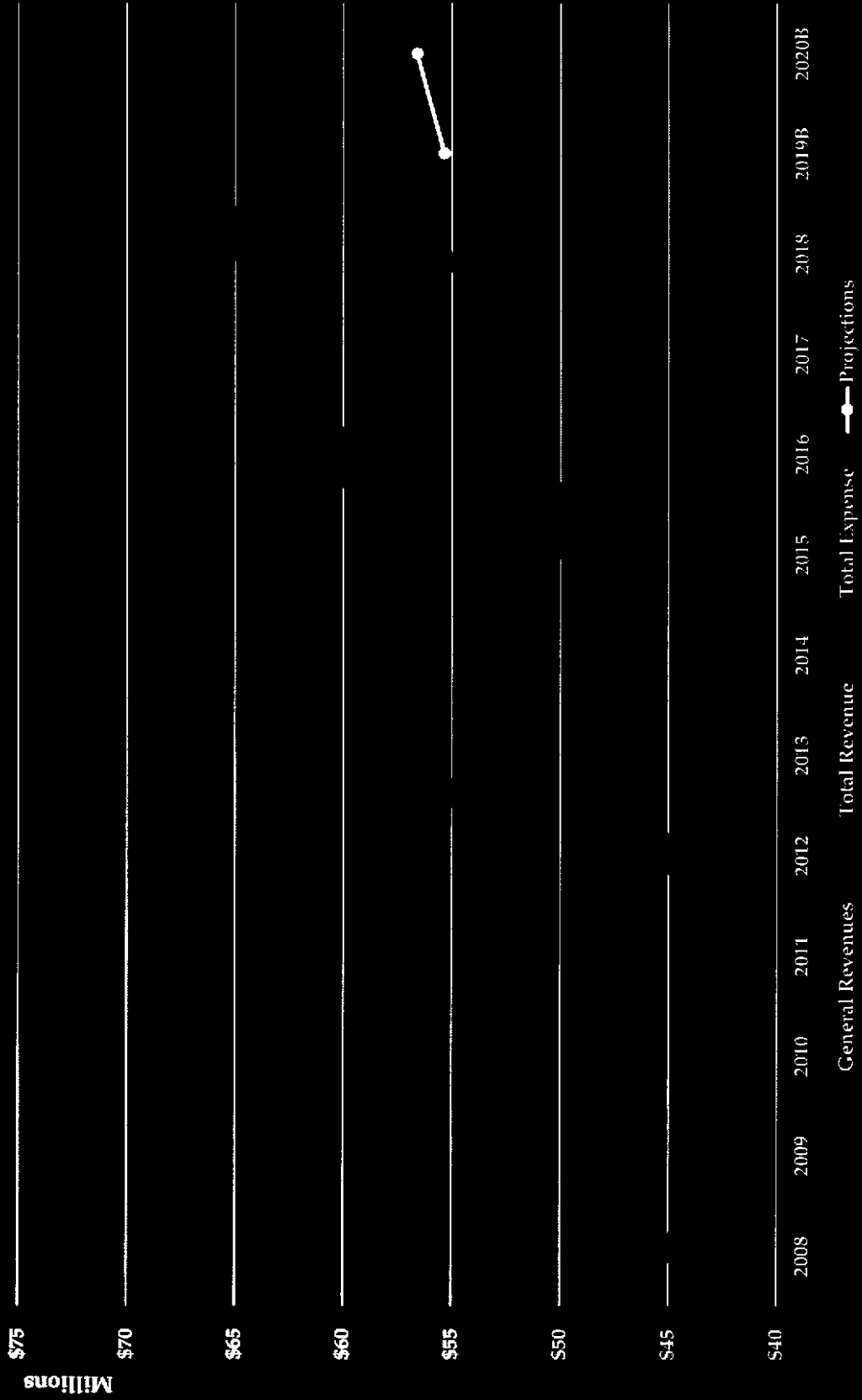

2020 Budget

Non-General Fund Budgets

▣ Projected Beginning Fund Balance	\$ 83,519,236
▣ Revenue Projections	<u>\$170,254,292</u>
▣ Available Resources	\$253,773,528
▣ Projected Expenses	\$192,762,568
▣ Projected Ending Fund Balance	<u>\$ 61,010,960</u>
▣ Use of Resources	\$253,773,528

2020 Budget

All Funds Total

- ▣ Total Revenue Budget of \$237,092,968
- ▣ Total Expense Budget of \$261,659,875
-

Significant Changes from 2019

- ▣ \$ 1.40 million - General Fund
- ▣ \$ 2.50 million – SIED
- ▣ \$ 8.50 million – Fairgrounds Capital Projects
- ▣ \$ 3.30 million – Mental Health Sales Tax
- ▣ \$ 2.20 million - Homeless
- ▣ \$ 6.80 million - Public Services

2020 Budget All Funds Total

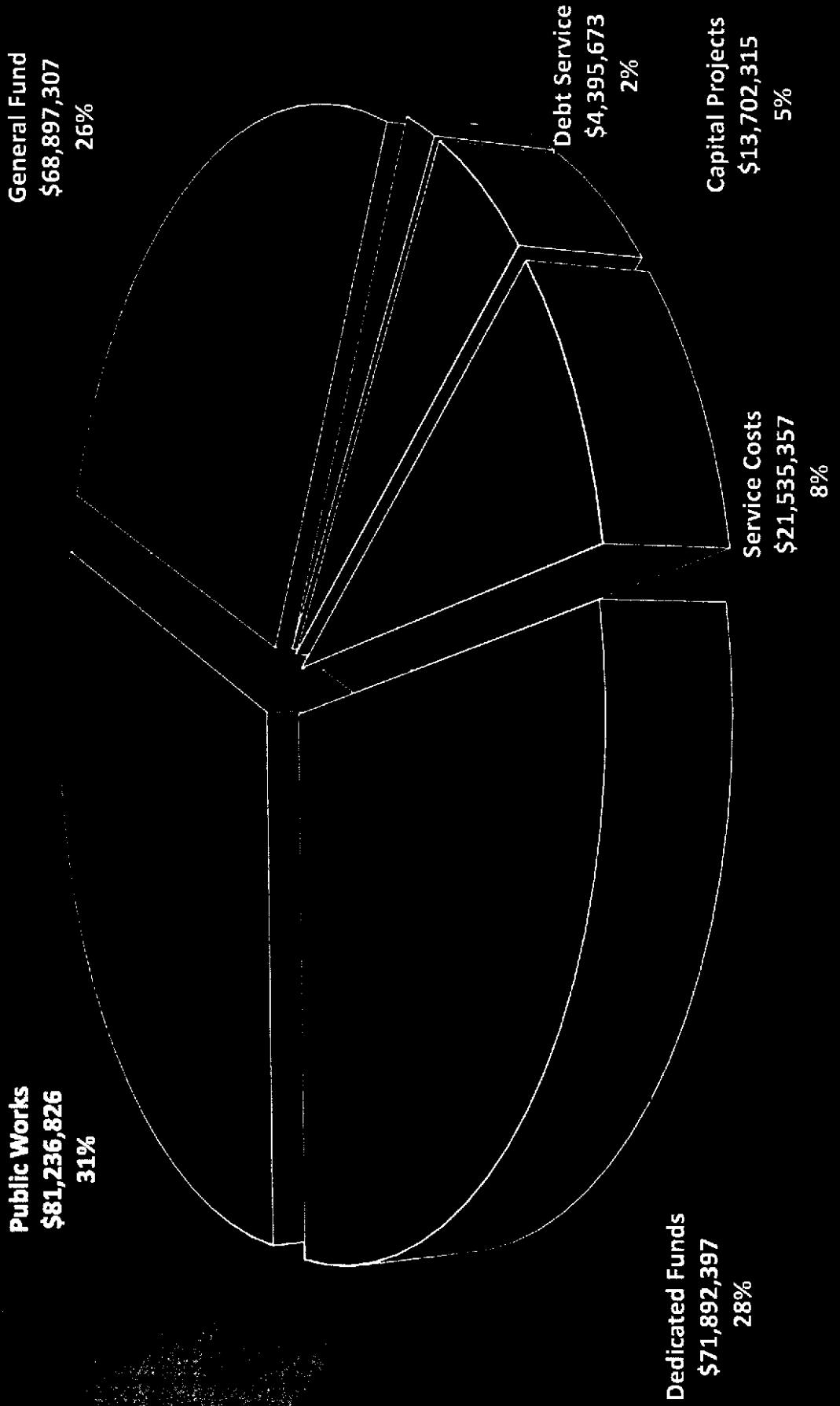

2020 Budget

- ▣ 2020 Budget Hearings
 - Tuesday, December 3rd at 10:30am
 - Wednesday, December 4th at 6:00pm

- ▣ 2020 Final Budget Adoption
 - Tuesday, December 10th at 10:00am

All meetings to be held in the City of Yakima Council Chambers (129 North 2nd Street, Yakima, WA)

2020 Budget

- ▣ Questions????
- ▣ Yakima County Commissioners
- ▣ (509) 574-1500
- ▣ Craig Warner, Financial Services Director
 -
 - (509) 574-1313