

| ROAD GRADE | RAMP LENGTH (12:1) |           |
|------------|--------------------|-----------|
|            | LOW SIDE           | HIGH SIDE |
| ≤ 1%       | 6'                 | 6'        |
| 2%         | 6'                 | 7'        |
| 3%         | 6'                 | 8'        |
| 4%         | 6'                 | 10'       |
| ≥ 5%       | 6'                 | 13'       |

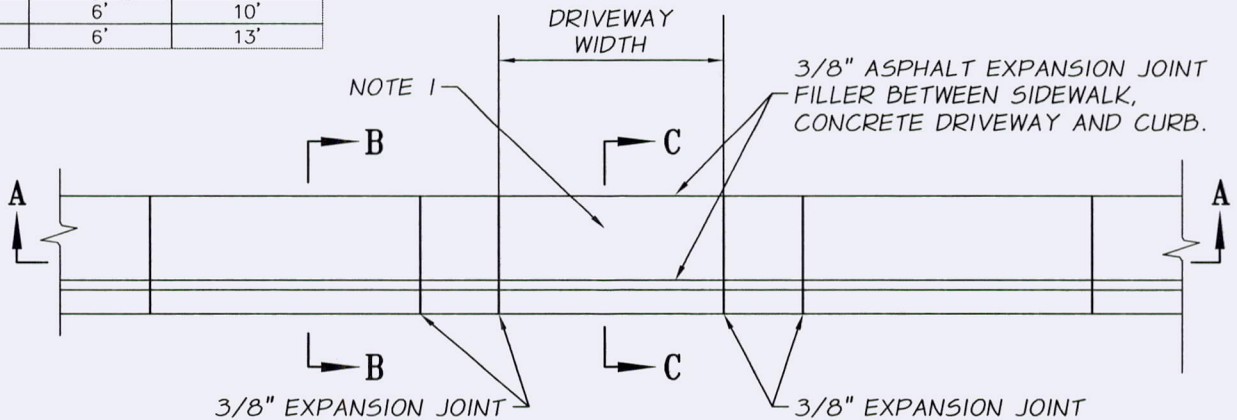

**TYPICAL DRIVEWAY ENTRANCE**  
NTS

**NEW DRIVEWAY WIDTHS:**

- 1) RESIDENTIAL DRIVEWAYS: WIDTH SEE PLANS
- 2) DEPRESSED DRIVEWAYS MUST BE SEPARATED BY AT LEAST 20.0' OF FULL HEIGHT CURB (ANY DEVIATIONS MUST BE APPROVED BY THE COUNTY ENGINEER).
- 3) FOR MOUNTABLE CURBS, SIDEWALK 0.5' MINIMUM THICKNESS.
- 4) PREMOLDED JOINT FILLER SHALL MEET THE REQUIREMENT OF SECTION 9-04.1 OF THE STANDARD SPECIFICATIONS.
- 5) FOR CEMENT CONCRETE DRIVEWAY DETAIL, SEE WSDOT STANDARD PLAN F80-10.-04, TYPE 1. WHEN THE DRIVEWAY WIDTH EXCEEDS 20' (FT), CONSTRUCT A FULL DEPTH EXPANSION JOINT WITH 3/8" (IN) JOINT FILLER ALONG THE DRIVEWAY CENTERLINE.

**CEMENT CONCRETE DRIVEWAY ENTRANCE**

APPROVED BY:

  
County Engineer:

3/10/2020  
DATE:

REVISION:

DESCRIPTION:

DATE:

| REVISION: | DESCRIPTION: | DATE: |
|-----------|--------------|-------|
|           |              |       |
|           |              |       |
|           |              |       |

STANDARD PLAN

**S-7**

SHEET 1 OF 2

